

Part 1

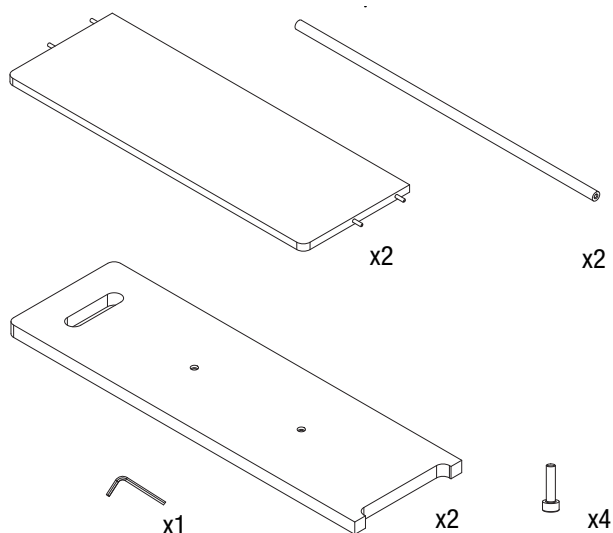

LIBRERO NESTOR

Equipo Santa&Cole

Accesorio
Accessory
Accessorie

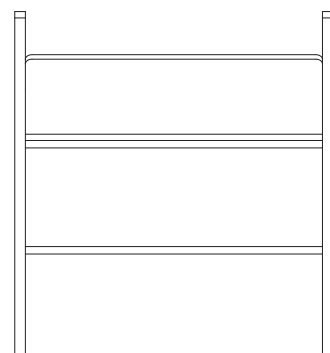

santacole.com

CARACTERÍSTICAS TÉCNICAS

Apta sólo para uso interior. Soporta hasta 35 kg
Peso: 7 kg



MANTENIMIENTO

Para el buen mantenimiento de la superficie, es suficiente pasar un paño suave, ligeramente humedecido con una solución jabonosa.
No utilizar nunca productos amoniacales, disolventes ni abrasivos, etc.

TECHNICAL CHARACTERISTICS

Suitable only for indoor use. Supports up to 35 kg
Weight: 7 kg



MAINTENANCE

For the best maintenance of its surface we recommend to clean it with a soft cloth, slightly damp with a soapy solution.
Never use an ammoniacal, solvents or alcohol.

CARACTÉRISTIQUES TECHNIQUES

Convient uniquement pour l'utilisation à l'intérieur. Supporte jusqu'à 35 kg
Poids: 7 kg

MAINTENANCE

Pour un bon entretien de la surface, il suffit de l'essuyer avec un chiffon doux, légèrement humidifié avec une solution savonneuse.
Ne jamais utiliser de produits ammoniacaux, de solvants, d'abrasifs, etc.

01

01.1

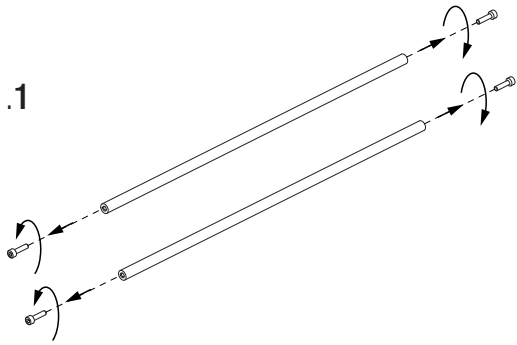

01.2

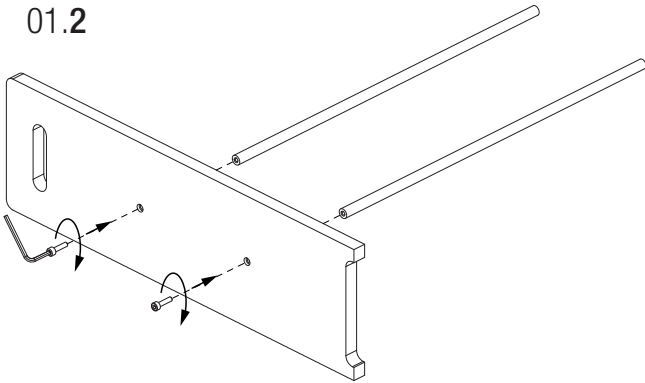

02

02.1

02.2

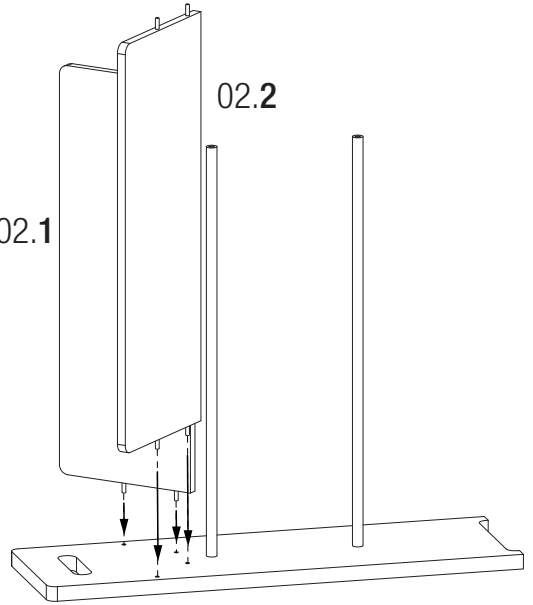

03

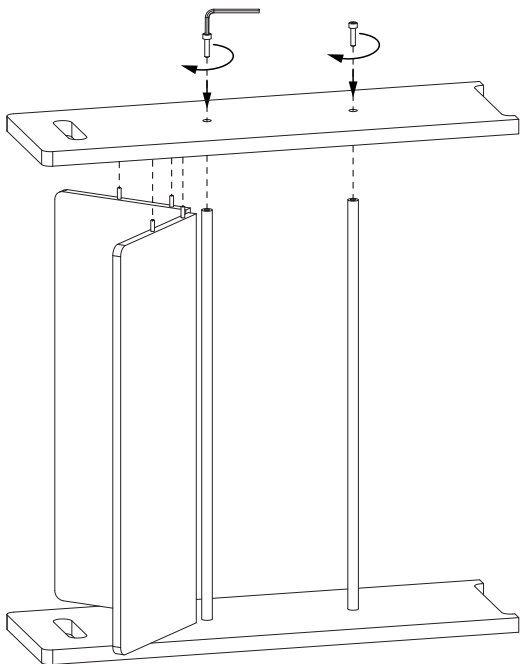

04

