

PRESS KIT
NEUE RÄUME
2015

All you have to do
is make the space
you live in more pleasant.
And the best way to do
so is to forget the lamps and
pay more attention
to the light itself.

Gabriel Ordeig Cole



SANTA & COLE



PRESS RELEASE

Press Department
Helena Tremoleda
comunicacion@santacole.com

Hallo Zürich

It is time to
excite with simplicity.

Santa & Cole is a small, independent and global publisher of well-designed products based in Belloch (Barcelona, Spain).

We are pleased to attend the 8th edition of Neue Räume fair and share with you this unique atmosphere to discover the latest trends and movements of the design field.

Welcome to our 'home',
we enjoy what we do.



We edit what excite us

PRESS RELEASE

Press Department
Helena Tremoleda
comunicacion@santacole.com

Our effort? Invite you to forget the lamps and
From our indoor novelties to our most emblematic classics you will see lamps from very different circumstances and intentions. A wide range of products that share a common intelligence: an accurate concept of good design and timeless quality. Objects that move us.

Therefore we dare to invite you to forget the lamps and pay more attention to the light itself. There it is our effort.



ARNE_01_CARLOS_PERICAS.jpg
 ARNE_02_CARLOS_PERICAS.jpg
 ARNE_03_CARLOS_PERICAS.jpg
 ARNE_04_CARLOS_PERICAS.jpg
 ARNE_05_CARME_MASIA.jpg
 ARNE_06_CARME_MASIA.jpg
 ARNE_07_CARME_MASIA.jpg
 ARNE_08_CARME_MASIA.jpg



ARNE DOMUS

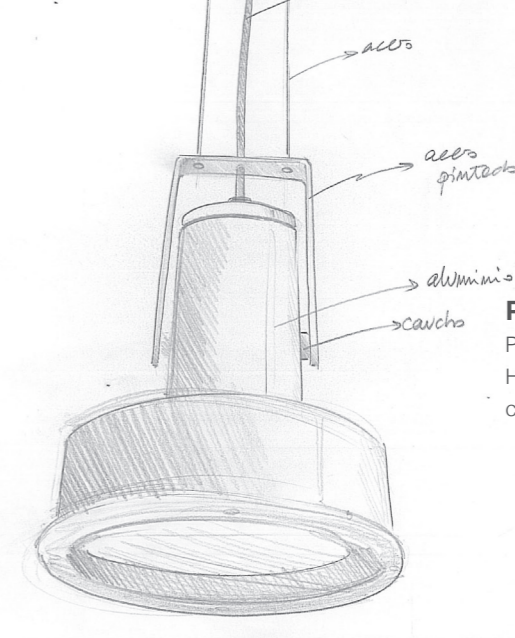

PRESS RELEASE
 Press Department
 Helena Tremoleda
 comunicacion@santacole.com

A hanging lamp and aluminium injection body to light small and large surfaces. Urban and elegant in equal measure, Arne Domus is a domestic spotlight with LED technology, designed in house by the Santa & Cole team. It is the expression of cutting-edge technology in its most natural form, and a modest tribute to the exemplary talent of Arne Jacobsen.



Santa & Cole Team.
 Formed by the people who collaborate in the technical department of Santa & Cole and captained by the editors, the Santa & Cole Team signs all the elements of own design. Examples include the Trípode lamp (1997), the Set Portes table (1999), the Nórdica lamp (1987), and the Humo ashtray (2007), among others.

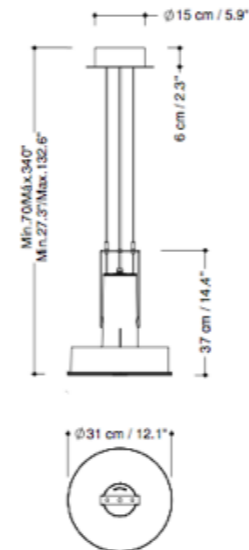





CIRIO_01_CARLOS_PERICAS.jpg
 CIRIO_02_CARLOS_PERICAS.jpg
 CIRIO_03_CARLOS_PERICAS.jpg
 CIRIO_04_CARLOS_PERICAS.jpg



CIRIO CHANDELIER

The Cirio family has grown with a new version of Chandelier. A compact and decorative design, repeatable to Versaillesque proportions, that radiates its warm LED candlelight to create an ambience in large spaces.

PRESS RELEASE
 Press Department
 Helena Tremoleda
 comunicacion@santacole.com



Antoni Arola
 Antoni Arola is nowadays one of the most outstanding figures in Spanish design. His work is characterized by its great versatility, which has allowed him to fulfill brilliantly the design either of a perfume bottle or of his renown lamps, or to undertake the interior design of modern indoor spaces. Arola was awarded the Spanish National Design Prize 2003.

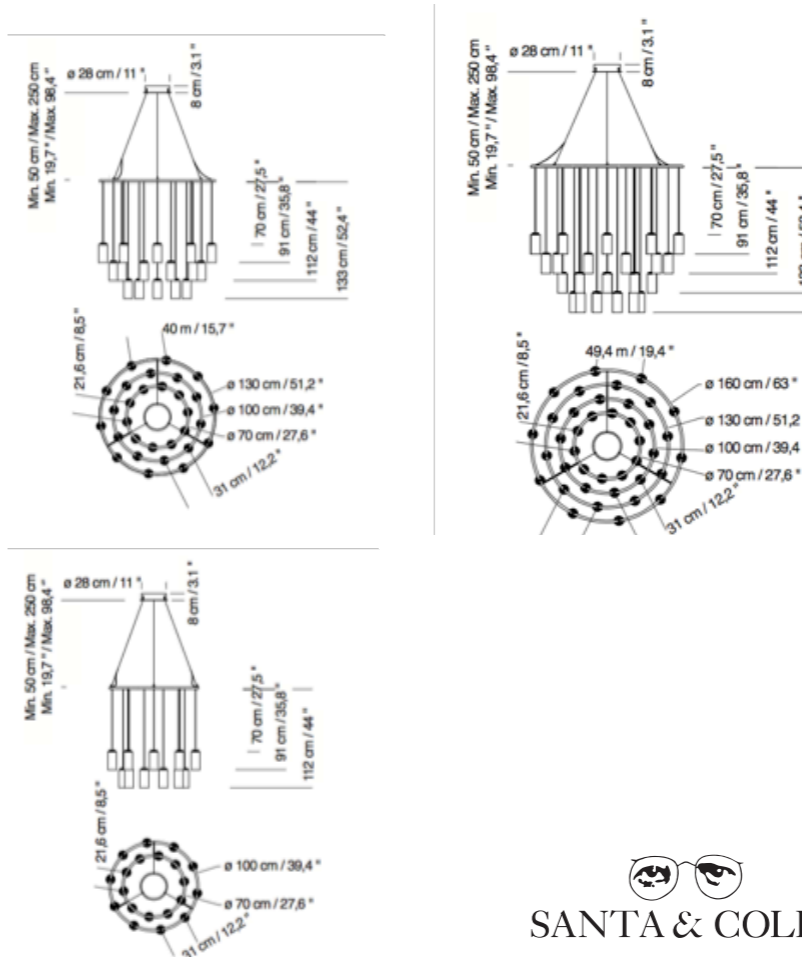



CESTA_METALICA_01_CARLOS_PERICAS.jpg
 CESTA_METALICA_02_CARLOS_PERICAS.jpg
 CESTA_METALICA_03_CARLOS_PERICAS.jpg
 CESTA_METALICA_04_CARLOS_PERICAS.jpg
 CESTA_METALICA_05_CARLOS_PERICAS.jpg
 CESTA_METALICA_05_CARME_MASIA.jpg
 CESTA_METALICA_06_CARME_MASIA.jpg

CESTA METÁLICA

A happy reinvention of the magic lantern, the Cesta family has grown with the latest re-edition based on the original 1962 design with a stainless steel structure and leather handle.

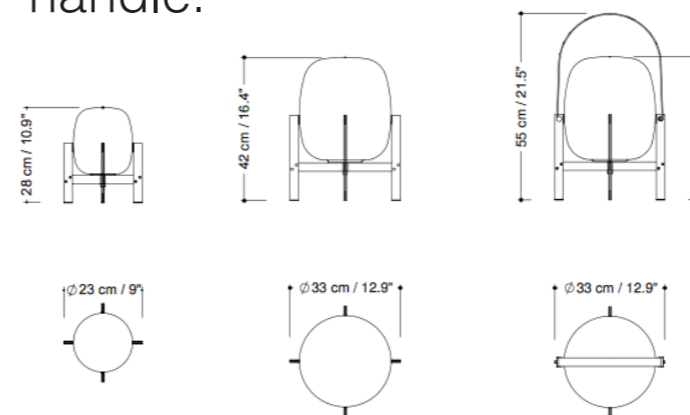

Cesta & Cestita

A magical hand-made lantern comprising a cherry wood structure that holds a light globe. Its oval volume and handle make it an object-lamp to be placed both on tabletops and floors.

PRESS RELEASE

Press Department
 Helena Tremoleda
 comunicacion@santacole.com



Miguel Milá

Miguel Milá represents like no other person Spanish contemporary design. He belongs to the pioneer's generation of the 50s, and has seen how many of his pieces of furniture and lamps have become real classics.



SIN_01_CARLOS_PERICAS.jpg
 SIN_02_CARLOS_PERICAS.jpg
 SIN_03_CARLOS_PERICAS.jpg
 SIN_04_CARME_MASIA.jpg
 SIN_05_CARME_MASIA.jpg
 SIN_06_CARME_MASIA.jpg
 SIN_07_CARME_MASIA.jpg



SIN

This is a lamp that owes its name to the many things it does without. Designed as the new basic Santa & Cole lamp, it marries tradition and technology with the sobriety of a classic. It is a circle of light in two sizes, with or without shade and has an adjustable light flow, to meet the lighting needs of any situation with great elegance.

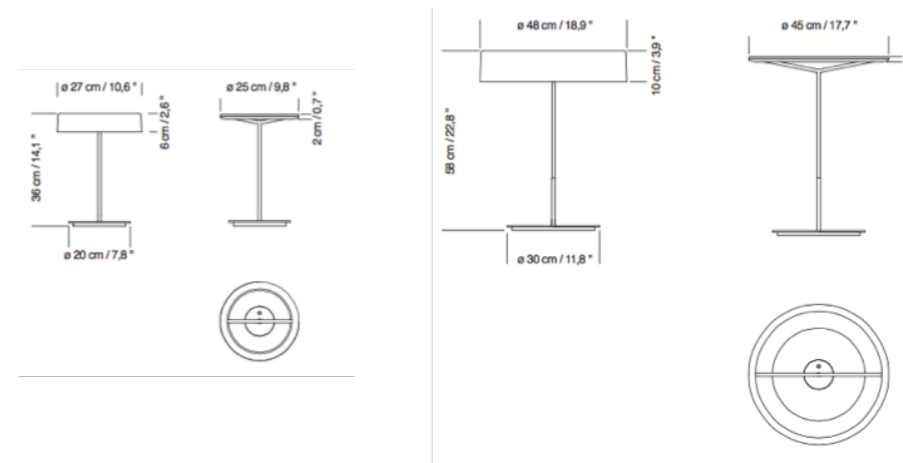

PRESS RELEASE

Press Department
 Helena Tremoleda
 comunicacion@santacole.com



Antoni Arola

Antoni Arola is nowadays one of the most outstanding figures in Spanish design. His work is characterized by its great versatility, which has allowed him to fulfill brilliantly the design either of a perfume bottle or of his renown lamps, or to undertake the interior design of modern indoor spaces. Arola was awarded the Spanish National Design Prize 2003.

MAIJA_01_CARLOS_PERICAS.jpg
 MAIJA_02_CARLOS_PERICAS.jpg
 MAIJA_03_CARLOS_PERICAS.jpg
 MAIJA_04_CARLOS_PERICAS.jpg
 MAIJA_05_CARLOS_PERICAS.jpg
 MAIJA_06_CARLOS_PERICAS.jpg
 MAIJA_07_CARME_MASIA.jpg
 MAIJA_08_CARME_MASIA.jpg
 MAIJA_09_CARME_MASIA.jpg
 MAIJA_10_CARME_MASIA.jpg



MAIJA

The warm, filtered light housed within the Maija series now with LED technology, in both the hanging and tabletop versions. We are also enlarging the series with a new smaller version of the famous Finnish classic.

In the language of Finnish functionalism, the Maija series conveyed the feeling of Baltic light from the inside outwards, with a graceful, durable structure reminiscent of the childish honeycomb of naughty honey bee Maya, the heroine of stories and cartoons that originally inspired its name. Maija was a very popular lamp from the outset. It was the only one made by this first major Finnish industrial non-architect designer after Alvar Aalto, and who is now recognised as a maestro of generations. An opaque body, fragmented into superimposed plates, filters and directs its happy inner light.

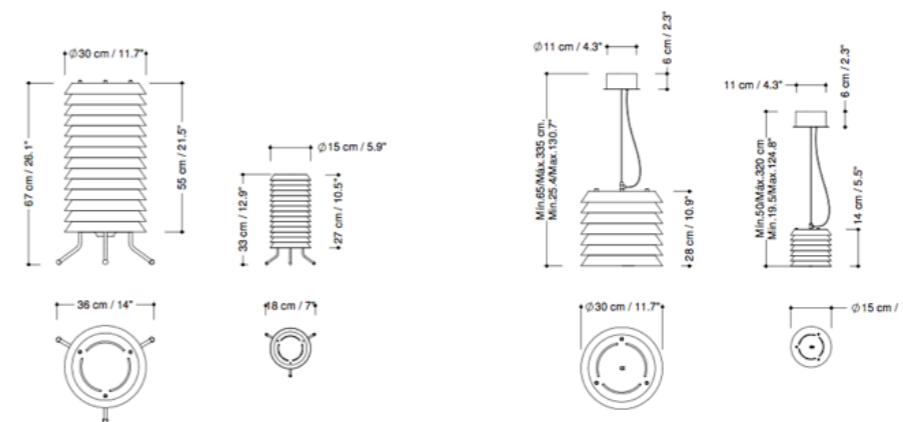

PRESS RELEASE

Press Department
 Helena Tremoleda
 comunicacion@santacole.com



Ilmari Tapiovaara

Hämeenlinna, 1914 - 1999
 Ilmari Tapiovaara is a pioneer in the new industrial design that arose after World War II, when it was no more a cultural luxury asset but spread to the whole of society.



ABOUT SANTA & COLE

PRESS RELEASE

Press Department
Helena Tremoleda
comunicacion@santacole.com

Since 1985, when Javier Nieto Santa, Gabriel Ordeig Cole and Nina Masó founded Santa & Cole, the company's raison d'être has been industrial design, an art consisting of seeking the best of each object to be able to offer a more pleasant experience in our daily life.

Santa & Cole's core business is based on seeking and choosing, from among a large number of objects, those with a great history which precedes them or with a humble surprise to be discovered, a selection which contributes more than just matter: peacefulness, culture and wellbeing.

Since its foundation, Santa & Cole has grown from a company wholly dedicated to design into a group which provides design-based project and management services for an international clientele.

Under its brand, it edits four types of products: indoor lighting and furniture products, books, urban lighting and furniture elements, and trees for urban reforestation. These four very different groups share, however, a common intelligence: the project professionals, both interior decorators and designers, architects and landscape gardeners interested in original high- quality contemporary design.

PRESS RELEASE

Press Department
Helena Tremoleda
comunicacion@santacole.com

Excite with
simplicity



SANTA & COLE