



SANTA & COLE

Collection for

landscapeforms®

landscapeforms®





Santa & Cole is a company based in Barcelona, Spain whose reason for being is to seek, nurture, and bring to market great industrial design. Since 1985 we have been committed to generating high quality products that improve the way we live in all our surroundings: in our public and private lives, at home, in the office, and in the city.

Coming of age during a time of great change in Spain, Santa & Cole has been a prominent participant in the renewal of the Barcelona streetscape and the city's emergence as an international design hub. For this work, Santa & Cole earned the 1999 Spanish National Design Award.



Our Lighting and Furniture Collections transcend national cultures and the interior / exterior divide - bringing the inside out, and transitioning from the house to the street to create open-air civic living rooms in numerous countries.

At Santa & Cole we have a vision of what public spaces and urban planning can be and how the elements in those spaces can contribute to the life of everyday citizens. We deliver on our promise to the planet by using recycled, recyclable and renewable materials; reducing energy use, maintenance, and the afterlife impacts of our products; and working with municipalities, utility companies and universities to develop sustainable practices for managing the city.

SANTA & COLE

Santa & Cole products are designed to enhance the experience of architecture, landscape and social encounter in the city. Our designs are subtle by design, rational and balanced.





Cities are shared territories. At a time when people use public spaces to expand the dwindling capacity of their homes, cities become coexisting spaces in which lighting and furniture elements help create better and more humane outdoor urban environments.

Santa & Cole Collection
for Landscape Forms



Nu bench at Race Street Pier, Philadelphia, PA (US). Project by James Corner Field Operations

10 Introduction

13 Lighting

14 **Arne**
Streetlight

18 **Candela**
Streetlight

22 **Rama**
Streetlight

26 **Skyline**
Beacon

33 Site Furnishings

34 **Bancal**
Bench

38 **Harpo**
Line

42 **Neocombo**
Bench

44 **Neoliviano**
Bench

46 **Neoromantico**
Bench

50 **Nu**
Bench

54 **Trapeccio**
Bench

56 **Bicilinea**
Bike Rack

58 **Humo**
Ash Urn

60 **Key**
Bike Rack

62 **Plaza**
Planter

64 Portfolio Line Art

66 Featured Projects

76 Belloch, Santa & Cole Headquarters

In the global village, it makes ever more sense to bring production closer to the end consumer: to strive to be local.



Celebrating 10 years of partnership

Landscape Forms, headquartered in Kalamazoo, Michigan, US and Santa & Cole, in Barcelona, Spain, inaugurated their partnership in 2006 and since then have together experienced the evolution of cities and the transformation of social interaction driven by new technologies. Ours is a strong relationship based on a shared vision for a more humane outdoor realm, and a common goal to actively participate in reimagining the 21st Century City.

In the global village, it makes ever more sense to bring production closer to the end consumer: to strive to be local. Today, in compliance with US regulations, a growing selection of Santa & Cole products – designed and developed in Barcelona – are locally manufactured at Landscape Forms' North American facility, reducing long distance transoceanic transport, minimizing environmental impacts, and enabling flexible delivery times.

Through our successful partnership, Santa & Cole products have been specified by Landscape Forms customers in numerous US and Canadian cities, proving once again that good design knows no boundaries. Both trusted brands are proud to stand behind these functional, elegant, and beautifully resolved collections of outdoor site furnishings and lighting.

landscapeforms®

SANTA & COLE



Lighting Collection

Santa & Cole understands lighting as one of urban design's primary tools for forging a new relationship between daytime and nighttime realities. Here, technique and creativity are vital if the wealth of urban space is to be experienced in its complex fullness.

In the shared urban and residential spaces, such as gardens, parks, paths, boulevards and historical centers, in which we coexist and spend much time, light is an essential

element that signals and modifies spaces. It creates effects and produces sensations that can help to define a more civil, peaceful and contemporary nocturnal cityscape.

Santa and Cole's Lighting Collection includes a wide variety of outdoor lights that encourage energy saving and minimize pollution while cultivating the aesthetics, light quality and functionality that enhance their capacity to dialog with spaces.





Arne

Santa & Cole Team

This simple floodlight has multiple applications and international appeal. It can be used as a pendant light, a wall-mounted lamp, a streetlight on a pole, or a floodlight fixed to a column. Equally at home in defined and open spaces, its elegantly clean form compliments traditional and contemporary architecture.

Arne is a versatile solution for lighting all aspects of the environment, from walkways and buildings to monuments and trees, and can incorporate various accessories to improve light comfort. The luminaire of recycled and recyclable aluminum is powdercoat finished.



Lighting supports for the Arne catenary model
with diffuser shade (available in 2018)



Sants Neighborhood, Barcelona (Spain) . More about the project P. 72

One luminaire, many options; varied requirements, multiple solutions. Arne offers a wide range of configurations.



Arne multiple pole attachment (available in 2018)

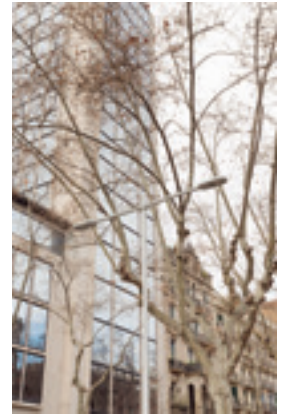

Passeig de Gràcia, Barcelona (Spain) . More about the project P. 68

Candela

Gonzalo Milá



**With its pure organic shapes,
Candela does not impose on the
cityscape - rather it enhances
light flow and broad distribution.**

Candela brings high design to LED lighting for the urban streetscape. Minimal in form, the oval-shaped luminaire is slim and sleek. Maximum in function, Candela offers high light output and reach with arrays of up to 96 energy-efficient LEDs, poles ranging in height from 26 to 32 feet tall, and arm supports in two lengths. Mount a single luminaire or two luminaires back to back or at different heights along the pole to achieve light levels tailored to the site.





Santa & Cole
corporate headquarters,
Barcelona (Spain)

Rama

Gonzalo Milá

Architectural in form and minimalist in expression, Rama is a “tree of light.” Rama is a striking and versatile pedestrian and street-scape light with ‘branches’ stemming from a trunk. It provides outstanding light quality, energy efficiency, and light pollution control. Rama allows multiple luminaries to be placed at different heights and positions on a single pole to put light where it is needed.







Bell Street Park, Seattle, WA (US)





DHUB - Design Hub, Barcelona, (Spain)

Architectural in form and minimalist in expression, Rama is a “tree of light.”



Skyline

Antoni Roselló

Skyline is an LED path light that combines color and light, international style and dramatic flair. A simple rectangular painted volume punctuated by a “window of light,” it illuminates the footpath, stairway, and architectural elements, and provides opportunities for layered lighting. Available in several shapes and sizes, with “windows” at different heights, for ground applications. Manufactured of structural steel and powdercoat finished.

A window of light for every step of the way.







Lighting drawings

Arne

P. 14

- Dark-Sky approved
- UL Listed
- Dimmable: 0-10V and DALI
- IP66 sealed cartridge (water/dust tight)
- Mounting Styles: Column, Catenary, Pendant, & Wall
- Power Supply: 120V-277V
- Color temperatures: 3000K / 4000K

Distribution Types:
Type II
Flood



UL RoHS

Wall



Catenary

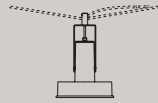

Arne fixed to a column:

Multiple pole attachment (single and double, available in 2018)

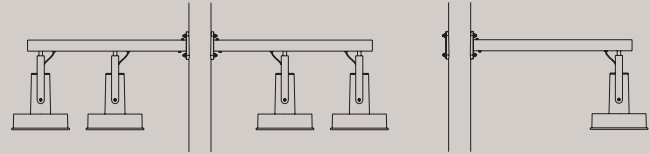

Pendant



Lighting comfort
Diffusing shade

Diffused lens (available in 2018)



Pole attachment (single and double)

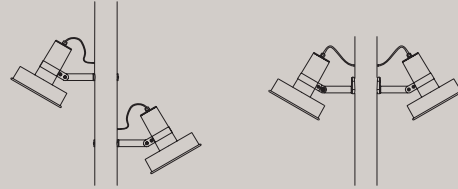

Candela

P. 18

- Dark-Sky approved
- UL Listed
- IP66 sealed cartridge (water/dust-tight)
- Power Supply: 120V-277V
- Single or Double Arm Mount
- Dimmable: 0-10V and DALI
- Color temperatures: 3000K / 4000K

Distribution Type II



UL RoHS

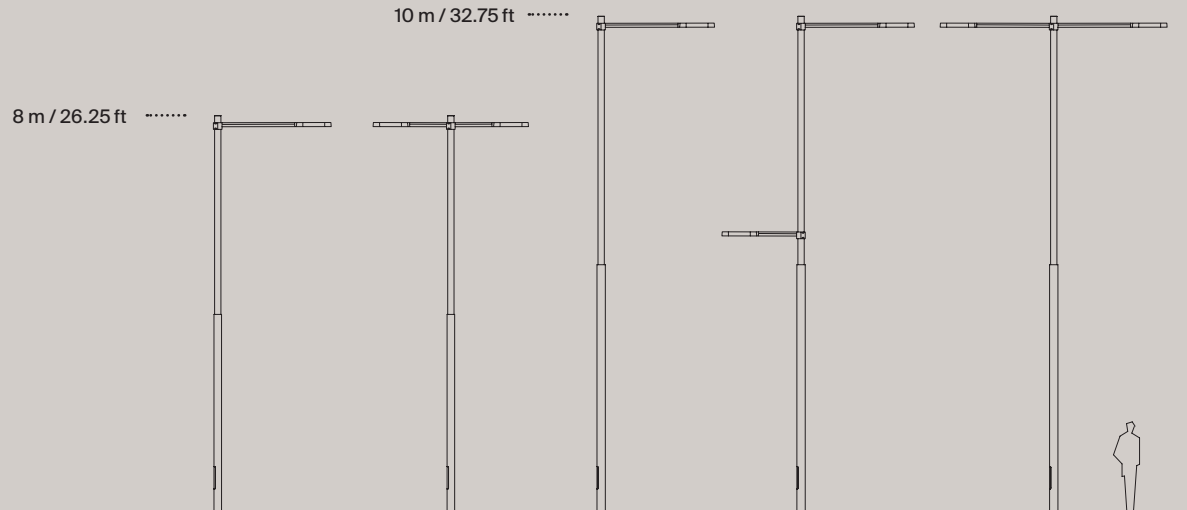

Skyline

P. 26

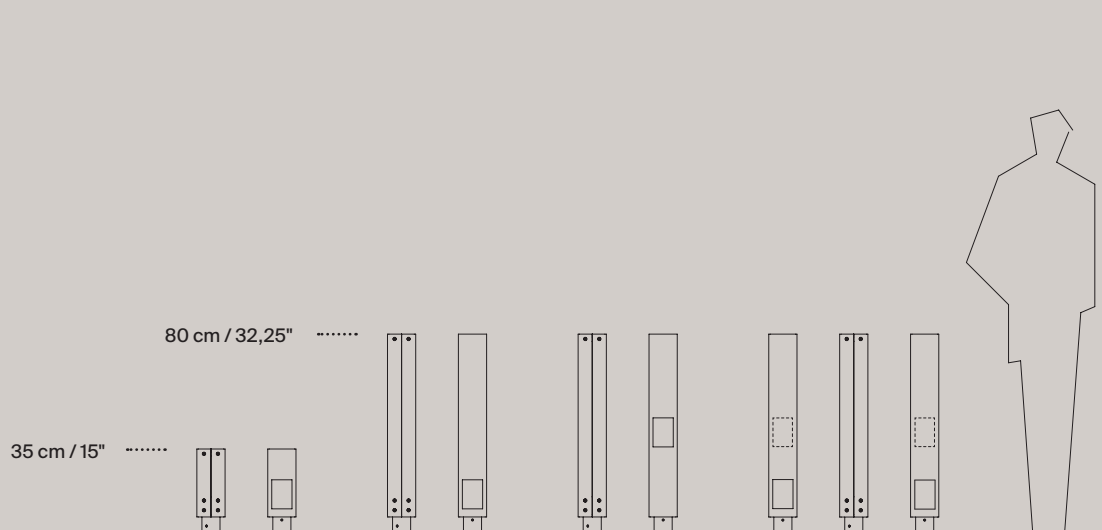

- UL Listed
- IP 65 sealed cartridge (water/dust-tight)
- Power Supply: 100V-277V
- Surface or Embedded mount
- Tempered glass diffuser lens
- Dual colored units available
- Color temperature: 3000K

Distribution Type I



UL RoHS

Rama

P. 22

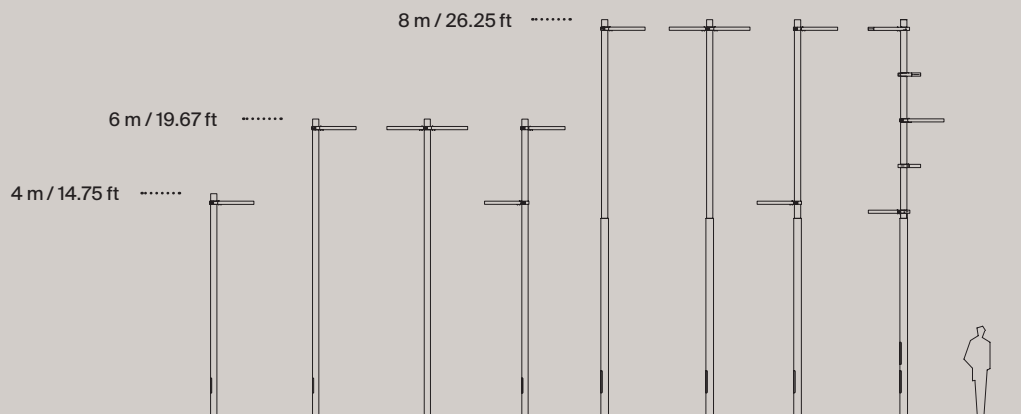

- Dark-Sky approved
- UL Listed
- IP66 sealed cartridge (water/dust-tight)
- Dimmable: 0-10V and DALI
- Clear or Frosted Lens
- Color temperatures: 3000K / 4000K

Distribution Types:
Type II
Type III
Type IV



UL RoHS

landscapeforms®

SANTA & COLE



Site Furnishings

Santa & Cole is committed to helping urban planners, architects and landscape architects transform public space into a more humanized environment. We are always mindful of the social interactions that happen around furniture elements. After trees, urban elements contribute the most to providing a sense of human proportion in outdoor space, softening the perception of the urban environment and providing identity and collective meaning.

The Santa & Cole Furniture Collection consists of elements that are understandable and functional, capable of shaping not only space but atmospheres and sensations.

Our furniture products, with their meticulous ergonomics, are elegant, simple and versatile. They encourage social interaction by enabling long rows and multiple configurations, with a variety of seating surfaces and materials that are durable and pleasant to the touch. These are elements that help to improve urban dwellers' quality of life.



**Modular, robust and maintenance free.
Bancal withstands adverse weather
with aplomb.**



Bancal

Julià Espinàs, Olga Tarrasó

Bancal is a modular and versatile bench for public meeting areas. Its flat steel plate structure supports a seat of wide wood boards that provides a large seating area. The optional wood board back is offset from the seat. Bancal is strong and robust in form and function. Durable, resilient and virtually maintenance free, Bancal is a bench for all seasons.



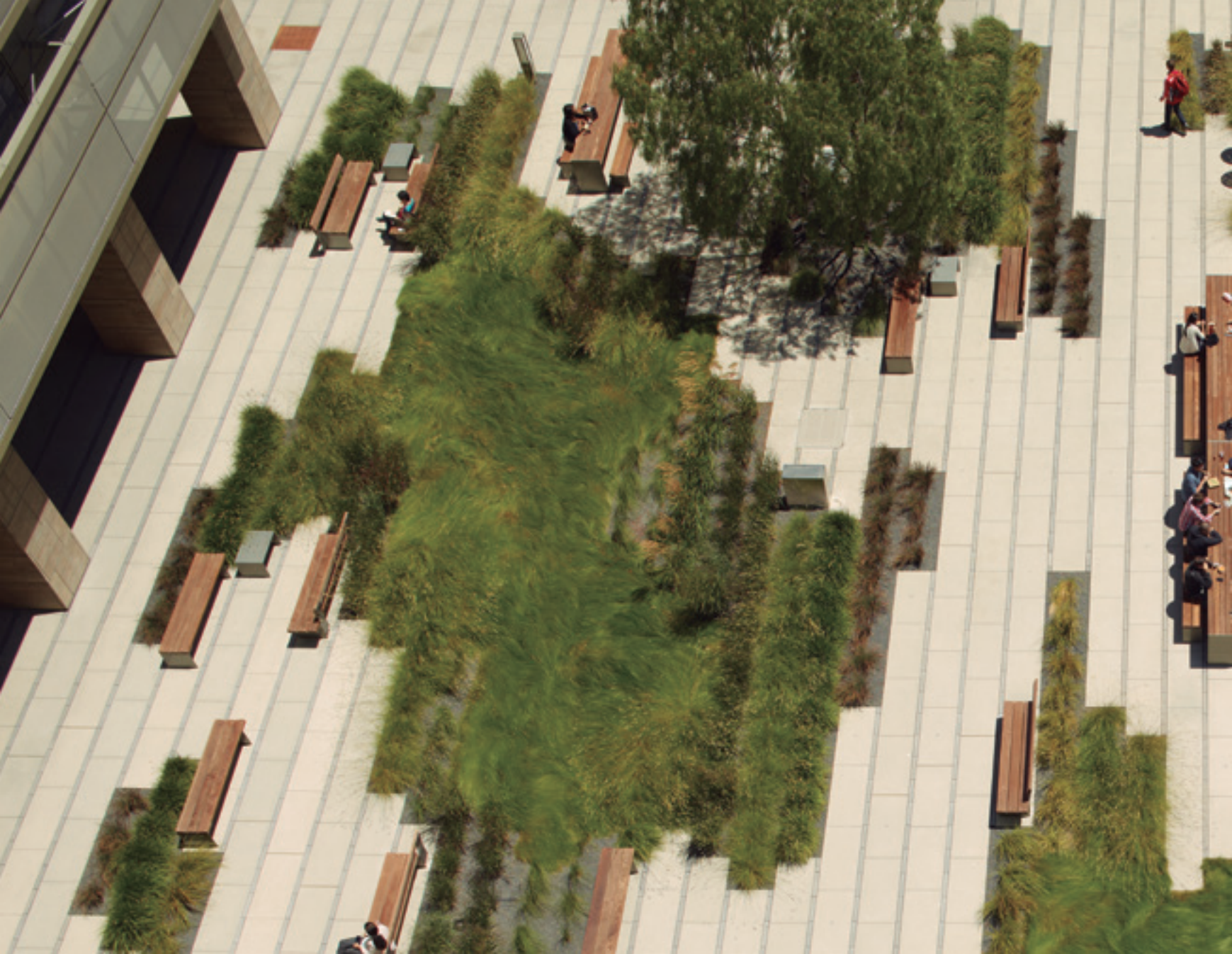

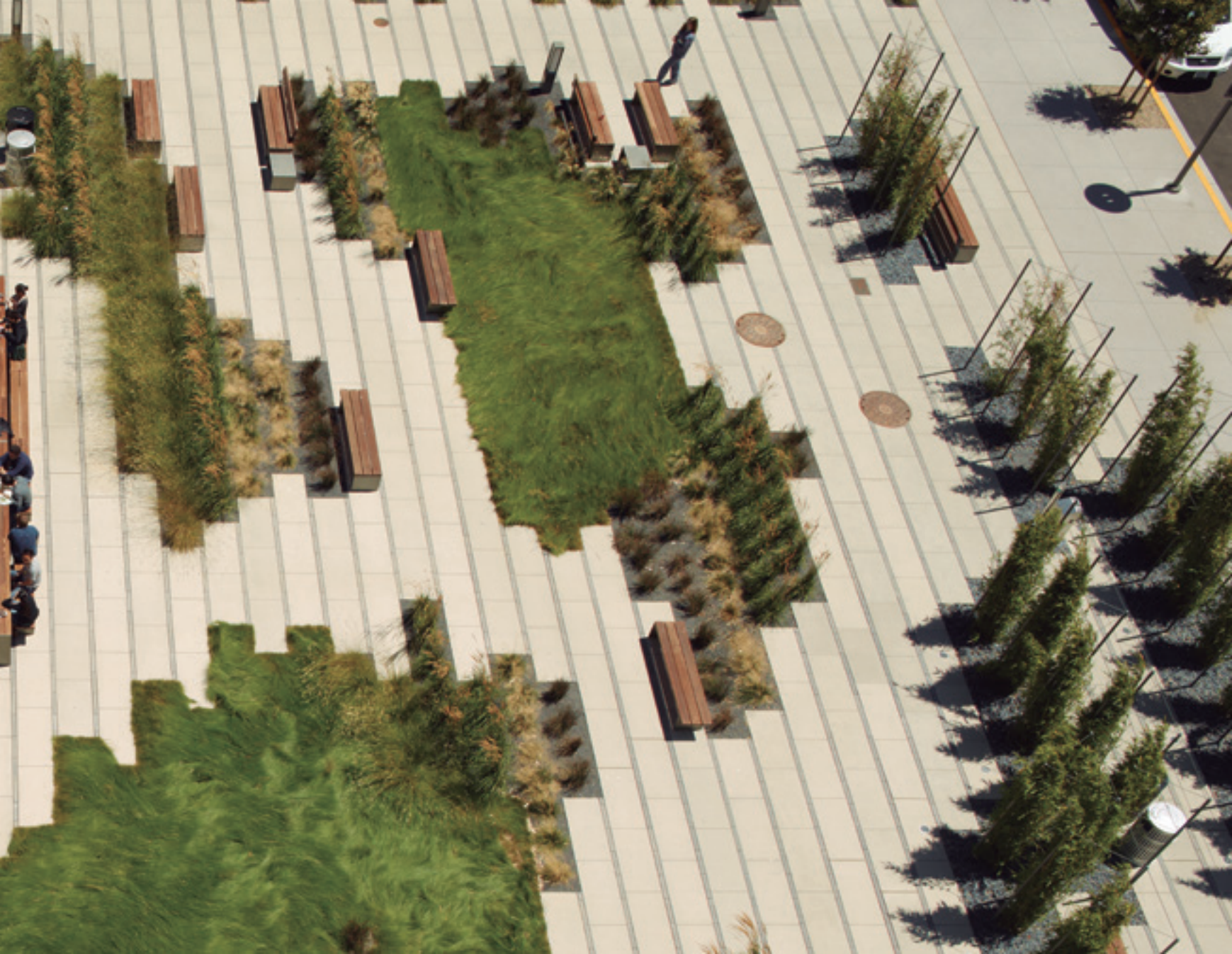



**Site furniture in an international language.
Design refined to its essentials.**

Harpo

Miguel Milá, Gonzalo Milá

Harpo is international in expression and universally applicable to streetscapes, public parks and private spaces. The visual language is pure, clean and architectural. Slim in profile and robust in structure, Harpo has formed and powdercoated steel frames with wood slat seats, backs and tops. The collection includes a short and long bench, with and without back and arms; a table for public picnic areas; a lounge chair with arms and high backrest; and a generous scale chaise lounge.



**The Harpo family: bench, table,
chaise lounge, lounge chair**







Neocombo

Miguel Milá

A strong bench with arms, Neocombo sits comfortably in its setting and provides a handsome complement to both soft and hardscapes. Neocombo's slim profile, light presence and recyclable aluminum material make it completely contemporary. Also available as a backless bench in several lengths.



**Completely contemporary.
A slim profile and light
presence in recyclable
aluminum.**





Passeig de Gracia Avenue, Barcelona (Spain). More about the project P. 68

Neoliviano

Miguel Milá

The Neoliviano bench is a lyrical variation on Neoromantico. Lighter in structure and form it has arms for extra comfort. Its slim profile coupled with a strong cast aluminum structure and wood slat seat and back make it versatile seating for both public and private spaces. The backless bench complements the family as a highly functional urban element to sit or lean on.

A light and lyrical bench with arms. Strong and versatile, for public and private spaces.







Its meticulous ergonomics and elegance have made Neoromantico our global best-selling contemporary urban design.

Neoromantico

Miguel Milá

A new interpretation of a venerable classic, Neoromantico brings the metal and wood city bench up to date. The seat and back of this elegant and ergonomic bench curve gently, supporting the body and creating a pleasing profile. Neoromantico has a strong, durable cast aluminum frame with wood slat seats and backs.





Nu

Jordi Henrich, Olga Tarrasó

Nu's large, flat platform of wood slats rests on a curved steel structure with legs grounded on circular steel plates. Offered backed and backless, with or without arms. The partial wood-slat back is mounted at the center of the bench, effectively creating backed and backless seating in a single element. Solid, austere, with straightforward lines, Nu is a classic in new urban design that can stand alone or be configured in rows to create comfortable resting places and bring order to outdoor space.





Barceloneta promenade, Barcelona (Spain)



Race Street Pier, Philadelphia, PA (US)





**Urban design at its best.
As meeting place or resting place,
Nu Bench becomes the place to be.**

**Nu Bench at Race Street Pier, Philadelphia, PA (US).
Project by James Corner Field Operations.**

Trapeccio

Antonio Montes, Montserrat Periel

**Seating in rare form.
Two long blocks of Alaska
Yellow Cedar offset to
create new opportunities
in urban leisure.**

An urban element that is more magnet for social activity than conventional bench. One can sit on the seat, or on the back, or lie down on it, and several people can do all these things at the same time. Ideal for public and private leisure areas. In any setting, the Trapecio bench is a stand-out.

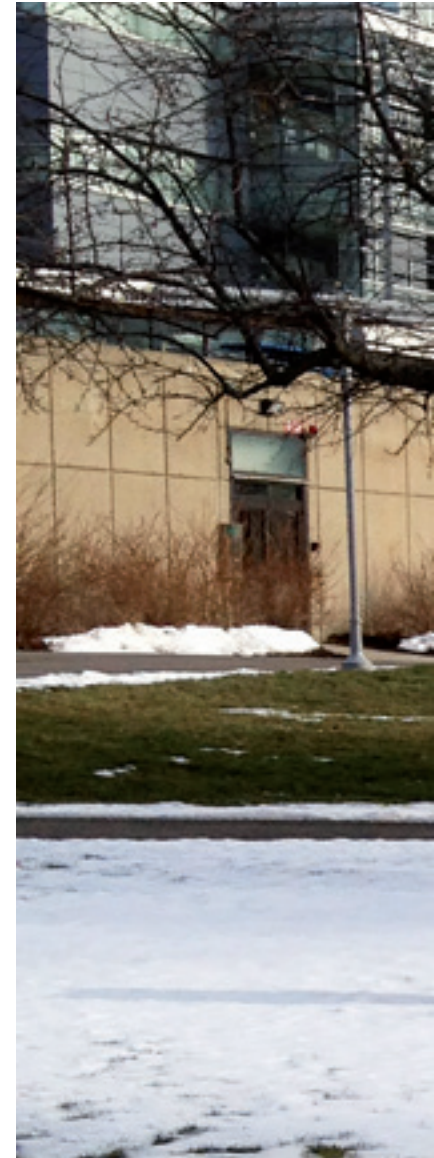

Brandeis University in
Waltham, Boston, MA (US)



Bicilinea

Beth Galí



An elegant solution to the growing need for bicycle parking in cities.

Curved arm sections mounted on a rectilinear rail provide strong support for multiple bicycles. Handsome in stainless steel. Bicilinea enables bicycles to be locked at both the frame and the wheel for added security.



Humo

Santa & Cole Team



An urban ashtray that's stately but not ostentatious. Strong, high capacity, easy to maintain. The tubular base and detachable head housing the ashtray container are all made of stainless steel.

Clean design, smoke and odor free, easy to maintain, and designed to be useful without standing out.





Recipient of a prestigious Red Dot Award, this simple and lighthearted bike rack updates an essential urban element with new spirit.

Key

LaGranja Design



Key is a bicycle rack with simple and friendly forms. Its steel loop frame, on a cast aluminum base, is finished in integral-colored high density polyurethane foam, providing a body that is pleasant to the touch, gentle to bicycle frames, and a humanizing element in the city. Works individually or in sets. Key is offered in cheerful yellow and red as well as anthracite grey.





Planters with large capacity and resilience, specially designed for trees and shrubs.

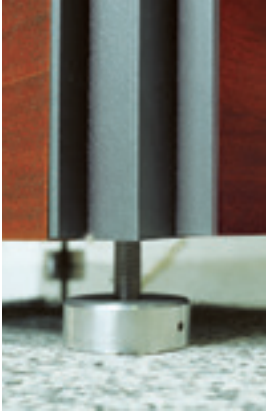

Plaza

José A. Martínez Lapeña, Elías Torres

These square planters in three sizes bring green to urban streetscapes and plazas where conventional planting is not feasible. Ideal for rooftop spaces. Plaza's rugged painted steel structure is complemented with infill panels in a choice of wood or steel. A fiberglass inner basin and strong metal mesh bottom make these planters highly functional as well as visually striking.

Site Furnishings

Bancal

P. 34

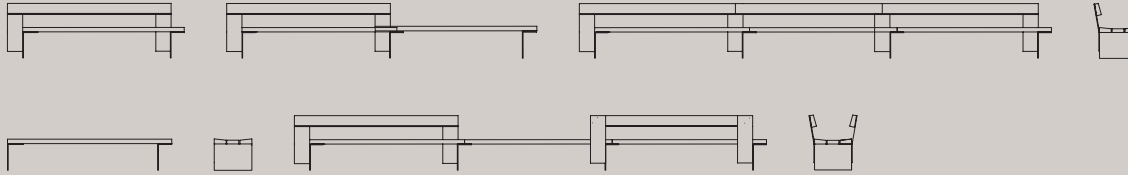

Harpo

P. 38

Bench



Table



Lounge Chair



Chaise Lounge



Neocombo / Neoliviano

P. 42



Neoromantico

P. 46



Nu

P. 50

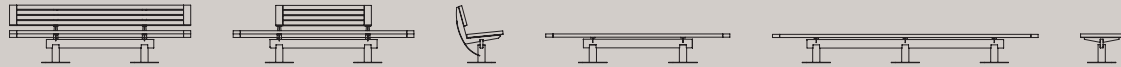

Trapezio

P. 54

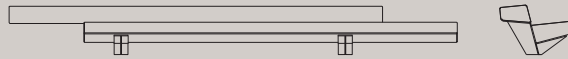

Bicilinea

P. 56



Humo

P. 58

Key

P. 60

Plaza

P. 62



landscapeforms®

SANTA & COLE



Featured projects



Redevelopment of Barcelona's main shopping avenue

Passeig de Gràcia Avenue, Barcelona (Spain)

Passeig de Gràcia, which boasts the highest concentration of modernist buildings in Europe, is at once an everlasting and ever-changing scene. While each succeeding generation showcases its luxury, modernity and tradition are serenely symbiotic: modernism, commerce and connectivity interweave with the splendor of the cosmopolitan city.

The very recent redevelopment has created wider pavements, replacing old benches with Miguel Milá's discretely dignified Neoliviano seating, which has been relocated to make better use of the new pedestrian spaces. The lighting for the central reservation and side lanes, which is the primary lighting for the entire boulevard, has been entrusted to the quiet and efficient Candela LED, a cutting-edge technology street lamp designed by Gonzalo Milá. As a result, Passeig de Gracia, now offers a more pleasant experience for residents and visitors in a highly elegant coming together of tradition and technology, architecture and design.



This project includes:
Candela street light (P. 18)
Neoliviano bench (P. 44)









Putting the train tracks underground

Sants neighborhood Barcelona, (Spain)

Over the last century, the historical train and metro tracks cutting through the Barcelona neighborhood of Sants have made a serious gash in its urban fabric, splitting the neighborhood from east to west into two isolated zones. The Sants railway urban renewal project included covering the tracks with a structure of diagonally placed pre-cast concrete blocks that transformed the space into a park, connecting the residents on each side of the tracks, improving quality of life, and reducing noise and vibrations from passing trains. Santa & Cole's Arne spotlight was chosen to light up the entire promenade. Its simplicity and versatility make it a perfect fit

and contribute to the quality of park users' experience. In addition, the iconic Neoliviano bench, designed by Miguel Milá, and the Rama street lamp, designed by Gonzalo Milá, were chosen to complement selected settings within the site and promote friendly social encounters.



This project includes:
Arne streetlight (P. 14)
Neocombo bench (P. 42)
Neoliviano bench (P. 44)







Belloch, Santa & Cole Headquarters

Parc de Belloch: A knowledge park

Santa & Cole's headquarters are in Belloch, a beautiful estate located in La Roca, 18 miles north of Barcelona. It is here that we pursue our core design development. The acquisition of Parc de Belloch led the company to launch its nursery activities, whose primary function is to help elevate the environmental quality of our cities, revitalize park land, and teach design with nature in mind. Santa & Cole's goal for Belloch is to promote a knowledge park oriented to academic learning and the best applied design in an environment of great architectural and natural quality.









Landscape Forms
7800 E. Michigan Ave. Kalamazoo, MI 49048
800.430.6209 landscapeforms.com

SANTA & COLE